



## SMC 33



### Safety muting controller

**!** Safety note:

- The safety muting controller SMC 33 can only be operated in connection with the test monitoring unit TNT 33.
- The SMC 33 muting controller fulfils the requirements of the safe bypassing circuit type 2 according to EN 61496-1.
- Maximum test response time of the muting senders Start 1 and Start 2 is 120ms for each sender.
- Extensive description is part of every shipment.

### Accessories

(available separately)

- Test-monitoring unit
  - TNT 33 (Part No. 500 28158)
  - TNT 34 (Part No. 500 81023)
- Testable muting sender suitable:
  - PRK 96 K/P-1361-29 (Part No. 500 80474)
  - PRK 97/4.8 L (Part No. 500 80474)
  - IPRK 92/4.8 S (Part No. 500 14199)
  - PRK 46/4.8-S12 (Part No. 500 60920)
- All throughbeam photoelectric sensors with (.8) activation input

### Features

- Connection to TNT 33 and TNT 34 test monitoring unit
- System self-test in connection with TNT 33 and TNT 34
- Processing of PLC control signals as muting sender
- Integrated direction identification
- Connection for monitored muting warning light (necessary acc. to EN 61496-1)
- Integrated self-containing mode (start with dimmed AOPD)

### Dimensional Drawing

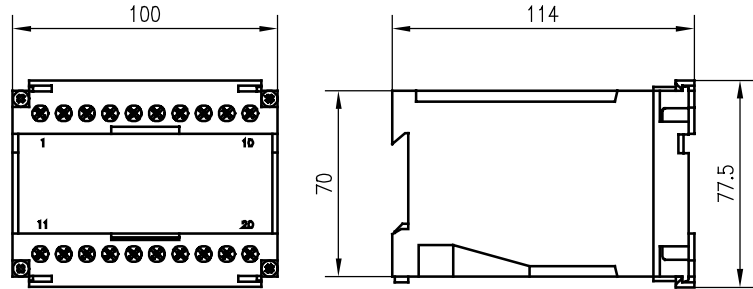

### Electrical Connection

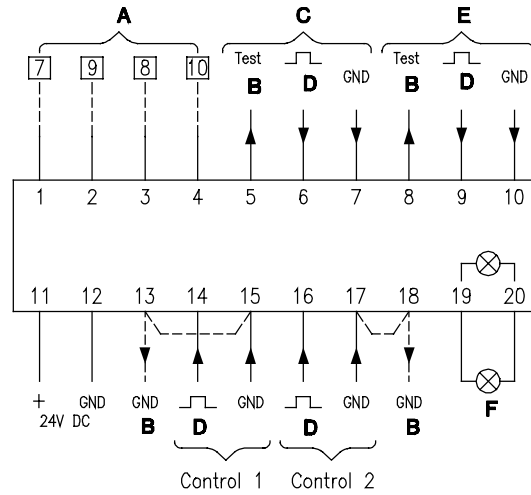

**G**

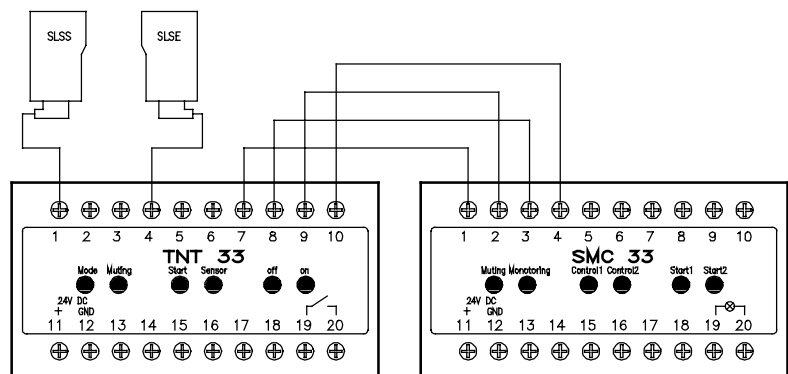

- A** TNT 33
- B** Output
- C** Start 1
- D** Input

- E** Start 2
- F** Muting lamp
- G** System architecture

602061-08/05 A000 Subject to change without prior notice



**Leuze lumiflex GmbH + Co.KG**  
 Liebigstraße 4  
 D-82256 Fürstenfeldbruck, Germany  
 Tel: +49 8141 5350-0  
 Fax: +49 8141 5350-190  
 e-mail: lumiflex@leuze.de  
 www.leuze.com



## Technical Data

Specifications	
Operating voltage $U_B$	24VDC $\pm$ 15% (incl. residual ripple)
Residual ripple	$\leq$ 15% of $U_B$
Current consumption	approx. 200mA (without muting light signal transmitter)
Inputs	
Test Input	PNP (HIGH active)
Muting preparation Control 1	PNP (HIGH active) <sup>1)</sup>
Muting preparation Control 2	PNP (HIGH active) <sup>1)</sup>
Input Start 1 (muting sender 1)	PNP (HIGH active) <sup>1)</sup>
Input Start 2 (muting sender 2)	PNP (HIGH active) <sup>1)</sup>
Outputs	
Muting output	PNP (HIGH active)
Test output Start 1	PNP (HIGH active)
Test output Start 2	PNP (HIGH active)
Muting light signal transmitter <sup>2)</sup>	N.O. contacts, 24 VDC, max. 2A connectable directly to SMC 33, integrated filament monitoring
Mechanical data	
Housing	polycarbonate, cover ABS/v-o gray
Connection	screw terminals max. connection cross section 2x2.5mm <sup>2</sup> acc. to DIN 46288
Mounting type	snap-on mounting on top hat rail
Weight	200g
Environmental data	
Ambient temp. (operating/storage)	-20°C ... +60°C/-30°C ... +70°C
Protection class	IP 40 (only for application in electrical operating rooms/switching cabinet with minimum protection class IP 54 is suitable)
Contact protection	acc. to VBG 4 and VDE 0106 part 100

1) Voltage free optical coupler input, input current approx. 5mA at 24V DC  
 2) Acc. to EN 61496-1 light density min. 200 cd/m<sup>2</sup>, light area min. 1cm<sup>2</sup>

## Muting system structure

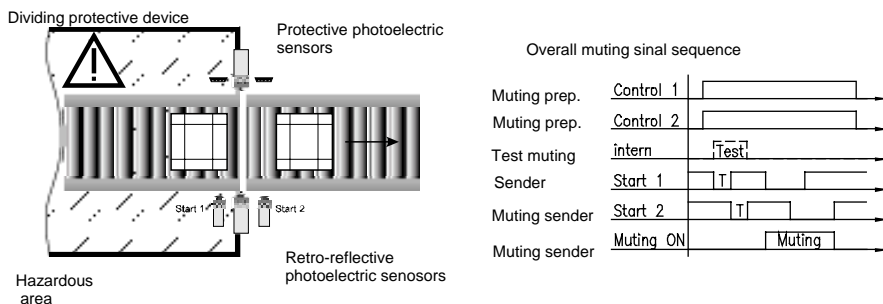

## Muting procedure

Before inducing a muting function, a test of the connected muting signal senders, e.g. retro-reflective photoelectric sensor with activation input, security switch with make-contact and break-contact or PCL control signals for the muting start and stop function via the muting preparatory signals of Control 1 and Control 2 is performed.

If using PLC, the muting preparation has to be made possible by different signal sources. With the SMC 33 a start of the unit can be performed even with dimmed protective photoelectric sensors. This "self-containing mode" can be induced with the start condition  $U_{B ON}$ , if using retro-reflective photoelectric sensors or security switches as muting sender. If using PLC control signals for muting start and stop, this "self-containing mode" can be performed without switching off the supply voltage.

The muting function starts with actuation of the first muting sensor "Start 1" and ends with the release of the second muting sensor "Start 2" and the switching off of the muting preparatory signals. A new muting process starts with the new activation of the muting preparatory signals.

## Order guide

Designation	Part No.
SMC 33	500 28157